

1. Introduction

Module **A-176 (Control Voltage Source)** provides three **voltage sources**, to use wherever an extra CV is required.

The top two voltage sources (**CV 1** and **CV 2**) have controls for **coarse** and **fine** control of the voltage output; the third source (CV 3) just has the one control.

The range of the voltages output can be preset, either to **0 to +5 V** or to **-2.5 V to +2.5 V** depending on your likely requirements. There is a jumper on the circuit board for each of the three voltage sources.

A typical use for the module would be to provide fine as well as coarse tuning for an A-110 standard VCO, (which, unlike the A-111, only has one tune control), See chapter 5, user examples.

In general, this module will be useful whenever you need a manually controllable CV on a module which doesn't itself have a built-in control.

2. Control Voltage Source - Overview

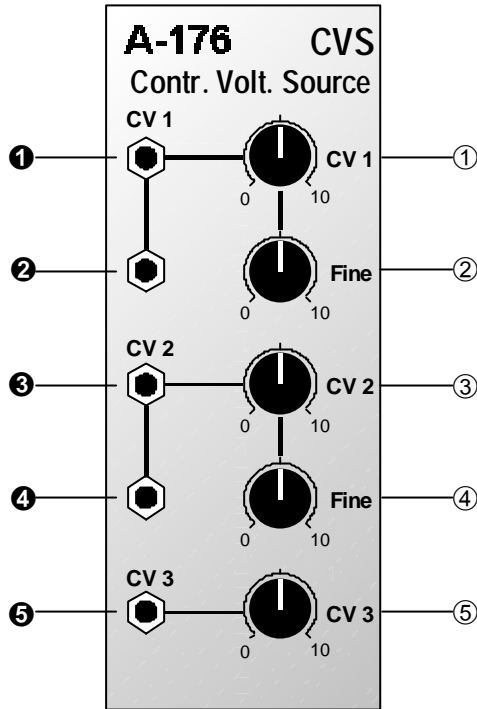

Controls:

- 1 **CV 1** : Coarse control for the voltage at linked outputs ! and "
- 2 **Fine** : Fine control for the voltage at linked outputs ! and "
- 3 **CV 2** : Coarse control for the voltage at linked outputs § and \$
- 4 **Fine** : Fine control for the voltage at linked outputs § and \$
- 5 **CV 3** : Control for the voltage at output %

Outputs:

- ! , " **CV 1** : Parallel outputs for CV source one
- §, \$ **CV 2** : Parallel outputs for CV source two
- % **CV 3** : Output for CV source three

3. Controls

1 CV 1 • 3 CV 2

Controls 1 and 3 provide **coarse adjustment** of the voltages at outputs ! and " , and § and \$ respectively.

The range of controls 1 and 3 is approximately **5 V**.

2 Fine • 4 Fine

Controls 2 and 4 provide **precision adjustment** of control voltages CV 1 (at outputs ! and ") and CV 2 (at outputs § and \$) respectively.

The range of controls 2 and 4 is approximately **0.1 V**.

5 CV 3

This knob sets the **control voltage CV 3**, at output %.

The range of this control is approximately **5 V**.

4. Outputs

! CV 1 • " CV 1

These are the internally connected **parallel outputs** for the **first CV source**, whose level is set by controls 1 and 2.

§ CV 2 • \$ CV 2

These are the internally connected **parallel outputs** for the **second CV source**, whose level is set by controls 3 and 4.

% CV 3

This is the **output** for the **third CV source**, whose level is set by control 5.

H The **voltage range for each of the sources** is individually adjustable with jumpers on the circuit board, either to **0 V - 5 V** or **symmetrical around zero** (-2.5 V to +2.5 V).

5. User examples

Expanding other modules' facilities

Module A-176 is always going to be useful when you need a manually controlled voltage which is not available on a particular module itself.

For instance, you can give the **A-132** low cost VCA manual control of its gain voltage, by patching in an A-176, and using the coarse and fine controls of one of its CV sources to set the gain (see Fig. 1).

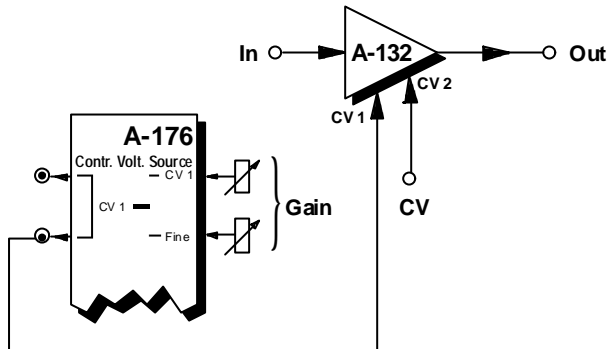

Fig. 1: Providing gain control for an A-132 VCA.

Improving tuning on the A-110 VCO

In contrast with the A-111 High End VCO, the A-110 standard VCO only has one control (Tune) for tuning. The range of this control has to be a compromise - it has a maximum range of only about an octave, but its fine tuning ability still isn't very precise.

With the A-176, it's possible to overcome these limitations, by patching the output from either the first or second voltage source into the CV2 input on the A-110 (see Fig. 2).

The VCO's frequency is then determined by a combination of the Range and Tune settings on the A-110, and the sum of the voltages going into the pitch CV input CV 1 and the external control voltage input CV 2.

Using the voltage source's coarse controller 1 or 3 you then have far wider manual control of the range of the A-110 at the selected footage; and with the voltage source's fine controller 2 or 4 you can fine tune the A-110 with great precision.

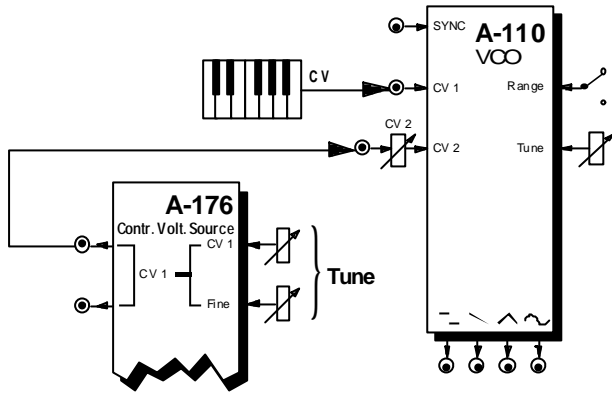

Fig. 2: Coarse and fine tuning an A-110 VCO.

Recalling pre-set CV values

Combined with an A-150 (or A-151) voltage-controlled switch, the A-176 can be used as a source of pre-programmed voltages.

A control voltage CV_s is patched into the A-150, and, depending on its voltage, sends CV1 or CV2 from the A-176 to the A-150's output. This original control voltage CV_s can come from a **MIDI controller** via an **A-190** or **A-191** MIDI interface. That can give you, for example, velocity or aftertouch switching of filter modulation intensity (see Fig. 3).

Control voltage CV_s can also come from a **sequencer** (for instance the A-160 / A-161 or MAQ 16/3), to change volume levels each time a pattern repeats.

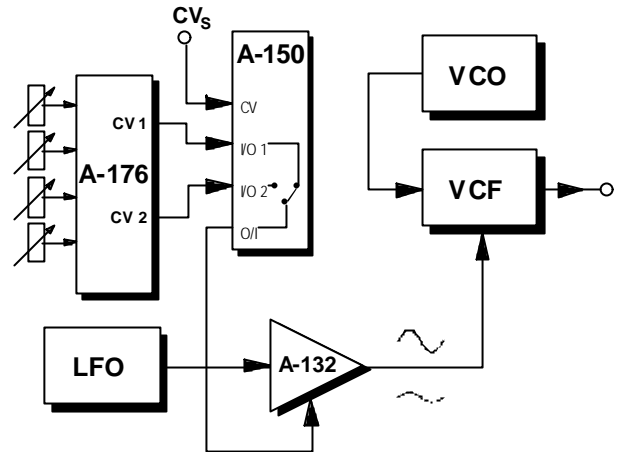

Fig. 3: Using a voltage-controlled switch to alternate between two pre-programmed modulation levels.

6. Patch-Sheet

The following diagrams of the module can help you recall your own **Patches**. They're designed so that a complete 19" rack of modules will fit onto an A4 sheet of paper.

Photocopy this page, and cut out the pictures of this and your other modules. You can then stick them onto another piece of paper, and create a diagram of your own system.

Make multiple copies of your composite diagram, and use them for remembering good patches and set-ups.

- P
- Draw in patchleads with colored pens.
 - Draw or write control settings in the little white circles.

